

## ***The Influence of Good Corporate Governance, Tax Planning, and Financial Distress on Earnings Management with Internal Control as Intervening Variable***

**Alfiana<sup>1</sup>, Fitriana Rakhma Dhanias<sup>2</sup>, Loso Judijanto<sup>3</sup>, Hadi Purnomo<sup>4</sup>, Dipa Teruna Awaludin<sup>5</sup>**

Universitas Muhammadiyah Bandung<sup>1</sup>

Universitas Brawijaya<sup>2</sup>

IPOSS Jakarta<sup>3</sup>

Universitas Mitra Bangsa<sup>4</sup>

Universitas Nasional<sup>5</sup>

[alfiana.dr@umbandung.ac.id](mailto:alfiana.dr@umbandung.ac.id)<sup>1</sup>, [fitriana.dhanias@ub.ac.id](mailto:fitriana.dhanias@ub.ac.id)<sup>2</sup>, [losojudijantobumn@gmail.com](mailto:losojudijantobumn@gmail.com)<sup>3</sup>,  
[hadipurnomo@umiba.ac.id](mailto:hadipurnomo@umiba.ac.id)<sup>4</sup>, [dipateruna@civitas.unas.ac.id](mailto:dipateruna@civitas.unas.ac.id)<sup>5</sup>

### **ABSTRACT**

*This study examines the influence of good corporate governance, tax planning, and financial pressure on earnings management in State-Owned Enterprises (SOEs) in Indonesia, with internal control as an intervening variable. This study is motivated by the limited research integrating the role of internal control in the relationship between governance mechanisms and earnings management, particularly in the context of SOEs. The study sample consisted of 20 SOEs listed on the Indonesia Stock Exchange during the 2018–2023 period, yielding 120 company-year observations selected via purposive sampling. Data analysis was performed using a random-effects model (REM) in EViews 12. The results show that corporate governance and financial pressure do not significantly influence earnings management, although both are negative. Tax planning has a significant negative effect on earnings management. Internal control is proven to have a significant negative effect, but is unable to mediate the relationship between the independent variables and earnings management. These findings emphasize the importance of strengthening internal control to suppress earnings management practices and provide an empirical contribution regarding the limited role of governance mechanisms in the context of SOEs.*

**Keywords:** *Good Corporate Governance, Tax Planning, Financial Distress, Earnings Management, Internal Control*

## **1. Introduction**

Amid the pressures of globalization and increasingly demanding performance standards, State-Owned Enterprises (SOEs) play a strategic role in the Indonesian economy, not only as business entities but also as instruments of public policy. However, in recent years, several cases of financial report manipulation in SOEs have raised doubts about the quality of financial reporting and the effectiveness of internal oversight mechanisms. This phenomenon indicates that earnings management practices remain a crucial issue, particularly because they can mislead stakeholders and damage a company's credibility (Marbun et al., 2021). Theoretically, earnings management practices are influenced by various factors, including good corporate governance (GCG), tax planning, and financial pressures (Putri et al., 2023). GCG is expected to limit opportunistic management behavior through the principles of transparency, accountability, responsibility, independence, and fairness. However, in the context of SOEs, the effectiveness of GCG is often questioned due to the complexity of ownership structures and the potential for political intervention, which could weaken oversight. Previous empirical studies have yielded inconsistent results: some found that GCG effectively suppresses earnings management, while others reported a weak or even positive effect. This inconsistency indicates

that GCG mechanisms may not be working optimally or may be influenced by other factors that are not yet fully understood (Poluan & Wicaksono, 2019).

Tax planning is also a significant factor driving earnings management. On the one hand, state-owned enterprises (SOEs) are responsible for contributing to state revenue through taxes. On the other hand, they are required to demonstrate good financial performance (Rachmawati & Fitriana, 2021). The tension between these two interests creates incentives for management to employ aggressive tax planning strategies that, in practice, can overlap with earnings manipulation. Although several studies have found a positive relationship between tax planning and earnings management, inconsistent results remain, indicating that the relationship is complex and contextual (Eryanto et al., 2022).

Furthermore, financial distress is a condition that, in theory, increases management's incentive to engage in earnings management, particularly to avoid breaching debt contracts or maintaining a high-performance image. In the context of SOEs, this pressure is further complicated by public performance demands and the possibility of government intervention. Most studies find that financial distress increases earnings management practices, but some show insignificant results, reinforcing an empirical gap that requires further exploration (Nabilah et al., 2024).

Although these three factors have been extensively researched, the relationships among them remain inconsistent. One major limitation in the literature is the lack of attention to the role of internal Control as a mechanism that can bridge this relationship. Internal Control can be a key factor in determining whether certain pressures or incentives translate into earnings management practices. However, research examining internal Control as an intervening variable, particularly in the context of state-owned enterprises (SOEs) in Indonesia, remains very limited and has not provided strong empirical evidence (Jesica, 2020; Prameswari et al., 2022). Financial distress can trigger earnings management practices in state-owned enterprises (BUMN) (Juliana & Reskino, 2023). The financial pressure faced by state-owned enterprises (BUMN) can stem from various sources, including increasingly fierce global competition, exchange rate fluctuations, commodity price volatility, and unfavorable macroeconomic conditions, such as those experienced during the pandemic. When facing financial distress, management often seeks to manipulate earnings to meet market expectations or avoid breaching debt agreements. Empirical data show that several state-owned enterprises (BUMN) experiencing financial difficulties exhibit more aggressive earnings management, particularly through discretionary accruals. This condition is exacerbated by the pressure to maintain credit ratings and access to external funding. (Ghonia & Darma, 2023; Suheri et al., 2020; Suwandi et al., 2024). A sample of state-owned enterprises (BUMN) (Juliana & Reskino, 2023) also provides empirical evidence that tax planning increases managers' potential to engage in earnings management, although the significance level is weak. However, the findings of Gulo & Mappadang (2022) actually produced contrary, albeit non-significant, findings: that Tax planning is not the main reason managers engage in earnings management.

Financial distress can also affect compliance with GCG principles, as management focuses on short-term survival rather than implementing good governance. Moreover, the status of state-owned enterprises (BUMN) as strategic companies often necessitates government intervention through state capital participation (PMN) or debt restructuring, which can create moral hazard in the company's financial management. Previous research findings generally show empirical evidence that financial distress exacerbates the situation, increasing the probability of earnings management (Jessica, 2021; Juliana & Reskino, 2023; Prameswari et al., 2022; Rosyanna et al., 2023; Wilamsari et al., 2022), although other studies show different significance levels with the same direction of relationship (Cahyaningrum et al., 2022; Ridanti & Suryaningrum, 2021). Conversely, findings with different significance levels were also reported by Tannaya & Lasdi (2021), Effendi (2019), who demonstrated that financial distress is not a crucial reason for managers to engage in earnings management.

Internal Control, as an intervening variable, plays a crucial role in mediating the influence of these factors on earnings management (Juliana & Reskino, 2023). A weak control system can create opportunities for earnings management, whereas a strong system can serve as an effective preventive mechanism (Ismail et al., 2024). Previous research on the influence of GCG, tax planning, and financial distress on earnings management has been extensive but has yielded inconsistent results. Moreover, the limited research using internal Control as an intervening variable, especially in the context of state-owned enterprises (BUMN) in Indonesia, makes this topic important for further investigation. Previous research used internal Control as a moderator in the relationship between financial distress and earnings management (Wilamsari et al., 2022).

Juliana & Reskino (2023) uses internal control as a mediator in the relationship between tax planning, financial distress, and earnings management. For GCG, the research reveals only the probability of internal Control as a mediating effect linking the influence of ownership structure to the integrity of financial statements (Ismail et al., 2024). Therefore, research that applies internal Control as a mediator is warranted to determine the mediation effect on the tested variables.

The period 2018-2023 was chosen as the research timeframe because it encompasses the pre-, during-, and post-pandemic periods. Many state-owned enterprises (BUMN) face challenges in maintaining their performance. This period also marks an era of digital transformation and strengthened BUMN governance, which can influence earnings management practices. Based on this background, this study aims to analyze the influence of good corporate governance, tax planning, and financial distress on earnings management with internal Control as an intervening variable in state-owned enterprises listed on the Indonesia Stock Exchange for the period 2018-2023.

Based on this gap, this study aims to analyze the influence of GCG, tax planning, and financial pressure on earnings management by incorporating internal control as an intervening variable. Focusing on SOEs is crucial due to their unique characteristics, namely a combination of profit orientation and public interest, as well as high governance complexity. Using data from SOEs listed on the Indonesia Stock Exchange during the 2018–2023 period, this study is expected to provide an empirical contribution by explaining inconsistencies in previous findings and expanding the literature on the role of internal control in limiting earnings management practices. Furthermore, this study offers practical implications for regulators and SOE managers to strengthen internal control systems and enhance corporate governance effectiveness.

## **2. Literature Review**

### **Good Corporate Governance and Earnings Management**

Good Corporate Governance (GCG) is a governance mechanism designed to ensure accountability, transparency, and effective supervision through structures such as boards of commissioners and audit committees. Based on Agency Theory, GCG reduces information asymmetry and limits managerial opportunism, including earnings management. Empirical studies by Ismail et al. (2024), Le & Nguyen (2023), Jesica (2020), and Nabilah et al. (2024) show that effective governance improves financial reporting quality and suppresses earnings manipulation. However, findings remain inconsistent because governance effectiveness depends not only on formal structures but also on implementation quality, institutional environments, political intervention, and ethical culture. Institutional Theory explains that governance mechanisms may become symbolic forms of compliance, particularly in State-Owned Enterprises (SOEs), where political pressures often weaken oversight effectiveness. Political Economy Theory further highlights that financial reporting decisions in SOEs are shaped by political interests and institutional power, while Stewardship Theory emphasizes ethical managerial responsibility. Sectoral differences also influence governance effectiveness, as

shown by Iqbal et al. (2023) and Saleh et al. (2023). Therefore, the relationship between GCG and earnings management is multidimensional and influenced by governance quality, institutional enforcement, political dynamics, and organizational culture.

*H1: Good Corporate Governance influences Earnings Management.*

### **Tax Planning and Earnings Management**

Tax planning refers to a company's effort to legally minimize tax liabilities through accounting and fiscal strategies. According to Agency Theory, tax planning can increase firm value but may also create opportunities for earnings management because managers possess discretion over financial reporting. Studies by Ghonia and Darma (2023), Suheri et al. (2020), Suwandi et al. (2024), and William & Widjaja (2024) show that aggressive tax planning often encourages earnings manipulation. However, other studies, such as Gulo & Mappadang (2022), report weaker or negative relationships, suggesting that tax planning does not always lead to opportunistic reporting. Positive Accounting Theory explains that managers strategically select accounting methods to balance tax efficiency and financial performance, while Institutional Theory highlights the role of regulatory pressure and legitimacy concerns in limiting manipulation. In SOEs, political accountability and public scrutiny often encourage more conservative tax behavior. Political Economy Theory explains that tax decisions are shaped by political and institutional pressures, whereas Stewardship Theory emphasizes ethical managerial responsibility in maintaining transparent reporting. Thus, the relationship between tax planning and earnings management depends on governance quality, institutional oversight, organizational objectives, and managerial ethics.

*H2: Tax Planning affects Earnings Management.*

### **Financial Distress and Earnings Management**

Financial distress refers to severe financial deterioration that threatens a company's operational continuity and ability to meet obligations. Agency Theory suggests that financial distress increases managerial incentives to manipulate earnings in order to maintain investor confidence, avoid debt covenant violations, and protect managerial interests. Empirical studies by Edi (2023), Jessica (2021), Juliana & Reskino (2023), Prameswari et al. (2022), Rosyanna et al. (2023), and Wilamsari et al. (2022) support the view that distressed firms often engage in earnings management. However, findings remain inconsistent because distressed firms also face stronger monitoring from auditors, creditors, and regulators, which may constrain manipulation. Positive Accounting Theory explains that managers may adjust accounting methods to avoid covenant violations, while Institutional Theory emphasizes legitimacy and external pressure that encourage conservative reporting. In SOEs, government support and public accountability often reduce incentives for aggressive earnings manipulation. Political Economy Theory explains that reporting practices are influenced by political interests and institutional power, while Stewardship Theory suggests that managers may prioritize organizational sustainability and transparency during crises. Research by Nestiti et al. (2025) and Prameswari et al. (2022) further shows that governance quality and organizational characteristics moderate the relationship between financial distress and earnings management. Therefore, the effect of financial distress on earnings management depends on the balance between managerial opportunism and governance, institutional, and political constraints.

*H3: Financial Distress affects Earnings Management.*

### **Internal Control and Earnings Management**

Internal control is a governance mechanism designed to ensure operational efficiency, regulatory compliance, asset protection, and reliable financial reporting. Through procedures such as segregation of duties, authorization systems, internal audits, and monitoring activities, internal control helps reduce fraud and managerial opportunism. Within Agency Theory, internal

control reduces information asymmetry and limits managers' ability to manipulate earnings for personal interests. Empirical studies by Cahyaningrum et al. (2022), Ismail et al. (2024), Ridanti & Suryaningrum (2021), Juliana & Reskino (2023), and Wilamsari et al. (2022) found that strong internal control reduces earnings management and improves financial reporting quality. However, Edi (2023) reported contradictory findings, suggesting that organizational pressure may still encourage earnings manipulation despite formal control systems. Institutional Theory explains that some organizations adopt internal control symbolically to achieve legitimacy rather than substantive accountability, creating "decoupling" between formal procedures and actual practices. Political Economy Theory further highlights that political intervention and bureaucratic influence in SOEs may weaken control effectiveness, while Stewardship Theory emphasizes the importance of ethical leadership and organizational commitment in strengthening internal control. Therefore, the effectiveness of internal control depends not only on procedures but also on implementation quality, governance environment, ethical culture, and organizational commitment.

*H4: Internal Control affects Earnings Management.*

### **Good Corporate Governance, Internal Control, and Earnings Management**

Good Corporate Governance (GCG) is a governance framework emphasizing transparency, accountability, responsibility, independence, and fairness to reduce agency conflicts and managerial opportunism. Earnings management occurs when managers manipulate financial reporting through accounting policies or accrual adjustments to achieve specific objectives. Internal control operationalizes governance principles through monitoring activities, risk assessment, authorization procedures, and internal audits, thereby reducing opportunities for earnings manipulation. Agency Theory explains that internal control mediates the relationship between GCG and earnings management by reducing information asymmetry and limiting managerial discretion. However, empirical findings remain inconsistent because governance effectiveness depends on implementation quality, organizational culture, and institutional pressures. Institutional Theory explains that governance and control systems may operate symbolically as ceremonial compliance, particularly in SOEs, where political and bureaucratic pressures influence managerial behavior. Political Economy Theory further highlights that governance mechanisms may lose independence due to political intervention, while Stewardship Theory emphasizes ethical leadership and organizational trust in supporting effective governance. Signaling Theory also suggests that strong governance and internal control provide positive signals regarding transparency and reporting quality. Empirical studies by Juliana & Reskino (2023), Jesica (2020), Prameswari et al. (2022), and Ismail et al. (2024) support the view that effective governance and internal control reduce earnings management. Therefore, internal control effectively mediates the relationship between GCG and earnings management only when governance mechanisms are substantively implemented and ethically supported.

*H5: Internal Control mediates the influence of Good Corporate Governance on Earnings Management.*

### **The Influence of Tax Planning on Earnings Management through Internal Control**

Tax planning is a strategy used by companies to minimize tax liabilities through lawful and efficient tax management. Agency Theory explains that managers may use accounting flexibility in tax planning to manipulate earnings while maintaining favorable financial performance. Positive Accounting Theory, particularly the political cost hypothesis, suggests that companies may reduce reported profits to minimize taxation and political scrutiny. Internal control plays an important role in ensuring that tax planning remains transparent, ethical, and compliant with regulations. Effective internal control systems reduce managerial discretion through approval procedures, monitoring, segregation of duties, and audit mechanisms, thereby

limiting opportunistic earnings management. Signaling Theory also suggests that strong internal control enhances stakeholder trust in tax planning activities. Empirical studies by Ghonia & Darma (2023), Puspito et al. (2017), Simbolon & Sudjiman (2022), Suheri et al. (2020), and Suwandi et al. (2024) found that aggressive tax planning tends to encourage earnings management. However, Juliana & Reskino (2023), Khairiyahtussolihah & Herawaty (2020), Ismail et al. (2024), and Sari & Karlina (2024) found that strong internal control reduces unethical reporting and improves transparency. Therefore, internal control acts as a mediating mechanism that weakens opportunistic earnings management associated with tax planning activities.

*H6: Internal Control mediates the influence of Tax Planning on Earnings Management.*

### **The Influence of Financial Distress on Earnings Management through Internal Control**

Financial distress refers to a condition where companies experience declining profitability, liquidity problems, and increased insolvency risk. Agency Theory explains that financial distress increases managerial incentives to manipulate earnings to maintain reputation, avoid debt covenant violations, and preserve investor confidence. Positive Accounting Theory, particularly the debt covenant hypothesis, suggests that distressed firms are more likely to adopt accounting methods that increase reported earnings. Signaling Theory also explains that managers may manipulate earnings to send positive signals regarding future performance. Internal control functions as a monitoring mechanism that strengthens transparency, accountability, and supervision over financial reporting. Strong internal control systems reduce opportunities for opportunistic earnings management by increasing detection risk and limiting managerial discretion. Stewardship Theory further emphasizes that effective control systems encourage ethical behavior and organizational responsibility. Empirical studies by Edi (2023), Jessica (2021), Ridanti & Suryaningrum (2021), Rosyanna et al. (2023), and Wilamsari et al. (2022) found that financial distress increases earnings management incentives. However, Juliana & Reskino (2023), Cahyaningrum et al. (2022), Wilamsari et al. (2022), Putri & Naibaho (2022), and Ismail et al. (2024) found that effective internal control weakens the relationship between financial distress and earnings management. Therefore, internal control serves as an important mediating mechanism that reduces opportunistic financial reporting during periods of financial pressure.

*H7: Internal Control mediates the influence of Financial Distress on Earnings Management.*

## **3. Methods**

### **Research Population and Sample**

The population in this study was all State-Owned Enterprises (SOEs) listed on the Indonesia Stock Exchange during the 2018–2023 period. The sampling technique used was purposive sampling, with the following criteria: SOEs consistently listed during the study period (2018–2023). Have complete and accessible annual financial reports. Present the required data for all research variables. The population of this study is state-owned enterprises (BUMN) listed on the Indonesia Stock Exchange for the period 2018-2023. The data used are secondary, in the form of annual financial statements. Data were obtained using documentation techniques accessed through the official website of the Indonesian Stock Exchange. The sample size of this research is 120 firm-years obtained from 20 BUMN companies. Some criteria were established as references for selecting the sample, so the purposive sampling technique was used in this research. The sample was then processed using Eview 12 by determining the effect model from the Chow, Hausman, and Lagrange Multiplier tests, which were used to proceed to the next testing stage. To test the mediation effect, path analysis was used to estimate the regression coefficients and standard deviations of the mediation variable and the variable affected by the

mediation, and the Sobel test was used to assess the mediation effect. The variables being tested are as follows:

Table 1 Operational Variables		
Variable	Operational Variables	Sumber
<b>Good Corporate Governance (X1)</b>	GCG refers to the framework of rules, practices, and processes that govern the company (GCG is proxied by institutional ownership).	(Iqbal et al., 2023; Jesica, 2020)
<b>Tax Planning (X2)</b>	Tax planning is the behavior of taxpayers who manipulate their financial statements within the framework of tax regulations to minimize their tax liabilities (Tax Planning is proxied by the Effective Tax Rate (ETR)).	(Suheri et al., 2020)
<b>Financial Distress (X3)</b>	Financial difficulties refer to situations that cause an individual or organization to be unable to meet their financial obligations or to experience difficulty in doing so (Financial Distress is proxied by the Altman Z-Score model).	(Wilamsari et al., 2022)
<b>Earnings Management (Y)</b>	A practice that involves the use of accounting policies and assessments by company management to manipulate financial statements (Earnings Management is proxied by Discretionary Accruals).	(Suheri et al., 2020)
<b>Internal Control (Z)</b>	Internal Control is a system designed to ensure the effective and efficient achievement of organizational goals (Internal Control is proxied by the Internal Control Disclosure Index (ICDI)).	(Juliana & Reskino, 2023)

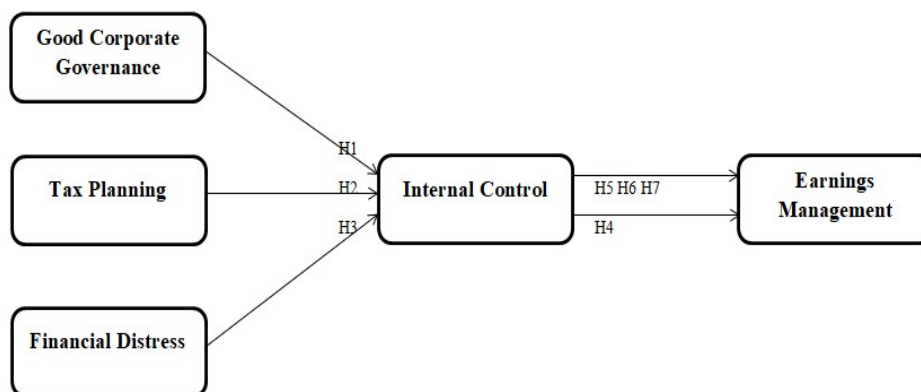

Figure 1 Framework

Based on these criteria, 20 SOEs were selected as the research sample. With a 6-year observation period, the total observations are: 20 companies × 6 years = 120 company-year observations. This explanation confirms the consistency between the number of companies and the number of observations, as noted by the reviewer.

### **Data Screening Procedure**

Before conducting the main analysis, the data underwent several screening procedures to ensure accuracy, completeness, and suitability for panel data regression and mediation analysis. First, all annual reports and financial statements of State-Owned Enterprises (SOEs) listed on the Indonesia Stock Exchange during 2018–2023 were collected and verified for completeness. Companies with incomplete financial data, missing annual reports, or unavailable information related to the research variables were excluded from the sample. Second, the collected data were checked for consistency, duplication, and data-entry errors. Observations containing inconsistent financial information or extreme reporting anomalies were revalidated using the original annual reports. After the screening process, 20 SOEs fulfilled all purposive sampling criteria, resulting in 120 firm-year observations. Third, classical assumption testing was conducted before hypothesis testing, including normality, multicollinearity, heteroscedasticity, and autocorrelation tests. These procedures were intended to ensure that the panel regression model met the statistical assumptions required for valid estimation and inference.

**Outlier Treatment.** Outlier detection was performed to minimize bias in the estimation results and improve the robustness of the statistical analysis. Outliers were identified using standardized residual values, boxplot analysis, and z-score criteria. Observations with z-score values exceeding  $\pm 3$  were categorized as potential outliers. To handle extreme values without significantly reducing the number of observations, this study applied winsorization at the 1st and 99th percentiles. This approach was selected because financial data from SOEs may naturally contain large fluctuations across industries and years. Winsorization helps reduce the influence of extreme observations while maintaining data distribution and preserving sample representativeness. Sensitivity analysis was conducted by comparing regression results before and after outlier treatment to ensure that the findings remained stable and statistically reliable.

### **Justification of Sample Adequacy for Mediation Analysis**

The adequacy of the sample size was evaluated based on the requirements for panel regression and mediation analysis. This study employed 120 firm-year observations derived from 20 SOEs observed over six years. According to mediation analysis literature, a sample exceeding 100 observations is generally considered sufficient to detect indirect effects using path analysis and the Sobel test, particularly when the model includes a moderate number of variables. The sample size satisfies the minimum recommendation for multivariate analysis, which suggests that the number of observations should be at least 10–20 times the number of estimated parameters. Since this study involves a limited number of independent, dependent, and mediating variables, the 120 observations are considered adequate to produce stable parameter estimates and sufficient statistical power.

The use of panel data also strengthens the analysis because it combines cross-sectional and time-series dimensions, thereby increasing the number of observations, reducing collinearity among variables, and improving estimation efficiency. Therefore, the sample size used in this study is considered statistically appropriate for testing both direct and indirect (mediation) effects involving internal control as an intervening variable.

In this study, bootstrapping was not applied due to several methodological and technical considerations related to the characteristics of the data and the analytical approach used. First, this study used a panel data regression approach with the EViews 12 application, which focuses more on estimating panel effect models through the Chow, Hausman, and Lagrange Multiplier tests before conducting mediation testing. In the context of panel data, the Sobel test is still widely used in accounting and financial management research because it is considered adequate for testing the significance of mediation effects based on the regression path coefficients obtained from the panel model. Second, the study's sample size was relatively limited, namely 120 firm-year observations from 20 state-owned enterprises over a six-year period. Although bootstrapping can be used for small to medium samples, applying

bootstrapping to panel data with a limited number of cross-sections has the potential to produce less stable resampling estimates, especially when the data distribution between companies is not homogeneous. Therefore, this study chose the Sobel test as a simpler approach and appropriate to the research data structure. Third, this study used explanatory quantitative research with the primary objective of testing causal relationships between variables based on theory and previous research. In many accounting and corporate governance studies, the combination of path analysis and the Sobel test remains an academically accepted method for evaluating mediation effects, particularly when the research model has a linear relationship and a single mediating variable. The Sobel test was chosen because it can measure the significance of indirect effects through direct estimation of regression coefficients and standard errors.

Furthermore, the use of bootstrapping is generally more optimal with SmartPLS- or AMOS-based approaches in Structural Equation Modeling (SEM) models. Meanwhile, this study used a panel regression approach with EViews, a more methodologically common approach, combined with the Sobel test for mediation testing. Therefore, the method selection was made to maintain consistency between the research design, panel data type, and analysis techniques used.

Nevertheless, this study recognizes the advantage of bootstrapping in increasing the robustness of indirect effect testing. Therefore, the use of bootstrapping is recommended for future research, particularly with larger sample sizes, SEM models, or more complex longitudinal approaches to achieve more robust and comprehensive mediation estimation results.

#### 4. Result and Discussion

##### Model Feasibility Analysis

Before proceeding to the classical assumption and hypothesis testing stages, measurement using Eviews requires the determination of the analysis model used, namely the Common Effect Model (CEM), Fixed Effect Model (FEM), and Random Effect Model (REM), through three types of tests, namely the Chow test, Hausman Test, and Lagrange Multiplier Test.

##### Chow Test

The criteria for determining the Chow test model are: if the probability is > 0.05, use the Common Effect Model (CEM); if the probability is < 0.05, use the Fixed Effect Model (FEM).

**Table 2. Chow Test Results**

Effects Test	Statistic	d.f.	Prob.
Cross-section F	3.293286	(19,96)	0.0001
Cross-section Chi-square	60.223600	19	0.0000

Based on the results of the Chow test above, it is known that the probability is 0.0001 < 0.05 with the previously established test criteria, so the Chow test concludes using the Fixed Effect Model.

##### Hausman Test

The Hausman Test criteria are: if the probability is < 0.05, use the Fixed Effect Model; if the probability is > 0.05, use the Random Effect Model (REM).

**Table 3. Results of the Hausman Test**

Test Summary	Chi-Sq.		
	Statistic	Chi-Sq. d.f.	Prob.
Cross-section random	3.449955	4	0.4855

Based on the Hausman test results above, the probability is 0.4855 > 0.05. With the previously established testing criteria, the Hausman test determines the Random Effect Model.

**Lagrange Multiplier Test (LM Test)**

The LM test criteria are that if the probability is > 0.05, then the Common Effect Model is used; if the probability is < 0.05, then the Random Effect Model (REM) is used.

**Table 4. Lagrange Multiplier**

	Test Hypothesis		
	Cross-section	Time	Both
Breusch-Pagan	19.67688 (0.0000)	2.117622 (0.1456)	21.79450 (0.0000)
Honda	4.435863 (0.0000)	-1.455205 (0.9272)	2.107643 (0.0175)
King-Wu	4.435863 (0.0000)	-1.455205 (0.9272)	0.729907 (0.2327)
Standardized Honda	5.322690 (0.0000)	-1.283895 (0.9004)	-1.173392 (0.8797)
Standardized King-Wu	5.322690 (0.0000)	-1.283895 (0.9004)	-2.184020 (0.9855)
Gourieroux, et al.	--	--	19.67688 (0.0000)

Based on the results of the Lagrange Multiplier test, the probability value (Breusch-Pagan) is  $0.0000 < 0.05$  with the previously established test criteria, so the LM test concludes using the Random Effect Model. Summary of the results of the three tests: Chow test (Fixed Effect Model), Hausman Test (Random Effect Model), and Lagrange Multiplier test (Random Effect Model). The next testing phase uses the random effect model as the reference model.

**Classic Assumption Test  
Normality Test**

The Normality Test in Eviews uses the Jarque-Bera probability value as a reference for determining the normality of research data: if the JB probability > 0.05, the data are normally distributed; if the JB probability < 0.05, the data are not normally distributed.

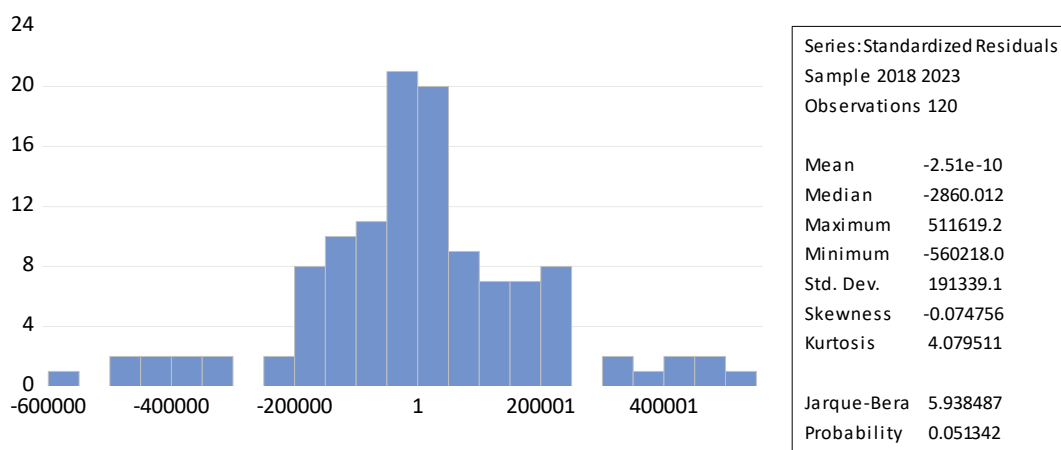

**Figure 2 Normality Test-Jaque Bera**

Based on the JB probability results above, which show a value of  $0.051342 > 0.05$ , the data are concluded to be normally distributed. And it can proceed to the stage of further classical assumption testing.

**Multicollinearity Test**

The criterion for testing multicollinearity is to identify the VIF value: if  $VIF > 10$ , there is multicollinearity; if  $VIF < 10$ , there is no multicollinearity.

**Table 5. Results of the Multicollinearity Test**

Variable	Coefficient	Uncentered	Centered
	Variance	VIF	VIF
C	1.97E+10	24.59904	NA
X1	2.78E+09	2.065055	1.045579
X2	9.25E+08	1.152315	1.010560
X3	0.033680	1.195828	1.045113
Z	3.000145	21.35137	1.050304

Based on the results of the Multicollinearity test above, the VIF value for Good Corporate Governance (X1) is 1.045579; the VIF for Tax Planning is 1.010560; the VIF for Financial Distress is 1.045113. All VIF values for the independent variables are < 10, indicating no multicollinearity.

**Heteroscedasticity Test**

The criteria for the heteroscedasticity test are that if the probability > 0.05, there is no evidence of heteroscedasticity, and if the probability < 0.05, there is no evidence of heteroscedasticity.

**Table 6. Results of the Heteroscedasticity Test**

Variable	Coefficient	Std. Error	t-Statistic	Prob.
C	233026.7	82619.95	2.820466	0.0056
X1	-14598.97	31568.86	-0.462448	0.6446
X2	-20773.20	22127.35	-0.938802	0.3498
X3	0.099229	0.120662	0.822372	0.4126
Z	-1.188354	1.013174	-1.172901	0.2433

Based on the results of the heteroscedasticity test above, the probability of Good Corporate Governance (X1) is 0.6446, the probability of Tax Planning is 0.3498, the probability of Financial Distress is 0.4126, and the probability of Internal Control is 0.2433. All the probabilities for these variables are > 0.05, so, based on the previous test criteria, it is concluded that there is no evidence of heteroscedasticity.

**Autocorrelation Test**

**Table 7. Results of the Autocorrelation Test**

Root MSE	147662.0	R-squared	0.448729
Mean dependent var	480135.9	Adjusted R-squared	0.316653
S.D. dependent var	199711.5	S.E. of regression	165091.1
Sum squared resid	2.62E+12	F-statistic	3.397519
Durbin-Watson stat	1.818198	Prob(F-statistic)	0.000014

Based on the results of the autocorrelation test above, the Durbin Watson value is 1.818198, with the dU value from the Durbin Watson table being 1.7536 and 4-dU being 2.2464. Therefore, with the previous test criteria  $dU < DW < 4-dU$  or  $1.7536 < 1.818198 < 2.2464$ , it can be concluded that there are no signs of autocorrelation.

**Hypothesis Testing**

**Table 8. One Model Regression Test**

Variable	Coefficient	Std. Error	t-Statistic	Prob.
C	75937.92	3942.714	19.26032	0.0000
X1	-3843.174	2398.831	-1.602103	0.1119
X2	1325.052	754.9093	1.755246	0.0819

X3	-0.011573	0.005509	-2.100787	0.0378
----	-----------	----------	-----------	--------

**Panel Data Regression Analysis**

$$Z = \alpha + \beta_1X_1 + \beta_2X_2 + \beta_3X_3 + e$$

$$Z = 75937.92 + -3843.174*X_1 + 1325.052*X_2 + -0.011573*X_3 + e$$

Referring to the results of the above equation, it is known that:

1. If the constant  $\alpha$  75937.92 is interpreted as the contribution of Good Corporate Governance, Tax Planning, and Financial Distress being 0 (zero), then the value 75937.92 is the value of internal Control.
2. The coefficient value for Good Corporate Governance is negative (- 3843.174). For every 1-unit decrease in Good Corporate Governance, Internal Control will increase by 3843.174.
3. The positive Tax Planning coefficient value of 1325.052 indicates that an increase of 1 unit in Tax Planning increases Internal Control by 1325.052.
4. The value of the Financial Distress coefficient, -0.011573, indicates that when Financial Distress increases by 1 unit, Internal Control increases by 0.011573.

**Table 9. Results of the Two-Model Regression Test**

Variable	Coefficient	Std. Error	t-Statistic	Prob.
C	784163.2	140381.9	5.585930	0.0000
X1	-384.2310	52760.42	-0.007283	0.9942
X2	-75112.67	30415.27	-2.469571	0.0150
X3	-0.100930	0.183520	-0.549969	0.5834
Z	-3.686918	1.732093	-2.128592	0.0354
Effects Specification				
			S.D.	Rho
Cross-section random			107145.3	0.2964
Idiosyncratic random			165091.1	0.7036
Weighted Statistics				
Root MSE	161228.2	R-squared		0.089901
Mean dependent var	255649.7	Adjusted R-squared		0.058246
S.D. dependent var	169712.5	S.E. of regression		164695.8
Sum squared resid	3.12E+12	F-statistic		2.839983
Durbin-Watson stat	1.548772	Prob(F-statistic)		0.027405
Unweighted Statistics				
R-squared	0.082088	Mean dependent var		480135.9
Sum squared resid	4.36E+12	Durbin-Watson stat		1.108910

$$Y = \alpha + \beta_1X_1 + \beta_2X_2 + \beta_3X_3 + \beta_4Z + e$$

$$Y = 784163.2 + -384.2309*X_1 + -75112.67*X_2 + -0.100930*X_3 + -3.686918*Z + e$$

Referring to the results of the above equation, it is known that:

1. The constant value ( $\alpha$ ) 784163.2 is interpreted as follows: when the contributions of Good Corporate Governance, Tax Planning, and Financial Distress are valued at 0 (zero), then 784163.2 is the value of Earnings Management.
2. The regression coefficient for Good Corporate Governance (GCG) is negative at -384.2309. This indicates an inverse relationship between GCG and earnings management. In other words, when the implementation or quality of Good Corporate Governance increases by one unit, Earnings Management tends to decrease by 384.2309 units, assuming other variables remain constant. Conversely, weaker governance quality is associated with a higher tendency for managers to engage in earnings management practices. Conceptually, this finding suggests that stronger governance mechanisms such as effective board oversight, transparency, accountability, and audit supervision are able to limit managerial

opportunistic behavior in financial reporting. Therefore, improved GCG implementation contributes to reducing the possibility of earnings manipulation and enhancing the credibility of financial statements.

3. The regression coefficient for Tax Planning is negative at -75112.67, indicating an inverse relationship between Tax Planning and Earnings Management. This means that an increase of one unit in tax planning is associated with a decrease in earnings management by 75112.67 units, assuming other variables remain constant. Conversely, lower effectiveness or intensity of tax planning tends to be associated with higher earnings management practices. This finding suggests that companies implementing more effective and compliant tax planning strategies may have less incentive to manipulate earnings because tax obligations can already be managed efficiently through legitimate fiscal strategies. As a result, the need for opportunistic financial reporting behavior becomes lower.
4. The regression coefficient for Financial Distress is negative at -0.100930, indicating an inverse relationship between Financial Distress and Earnings Management. This means that an increase of one unit in Financial Distress is associated with a decrease in Earnings Management by 0.100930 units, assuming other variables remain constant. Conversely, lower levels of Financial Distress tend to be associated with slightly higher Earnings Management practices. This finding suggests that companies experiencing lower financial pressure may still possess greater flexibility and discretion in managing reported earnings, whereas firms under severe financial distress may face tighter scrutiny from auditors, regulators, creditors, and stakeholders, thereby limiting opportunities for earnings manipulation.
5. The regression coefficient for Internal Control is negative at -3.686918, indicating an inverse relationship between internal control and earnings management. This means that an increase of one unit in the effectiveness of internal control is associated with a decrease in earnings management by 3.686918 units, assuming other variables remain constant. Conversely, weaker internal control systems tend to be associated with higher earnings management practices. This finding suggests that effective internal control mechanisms — such as supervision, segregation of duties, monitoring procedures, and accurate financial reporting systems — can reduce managerial opportunities to manipulate earnings and improve the reliability of financial statements.

**Coefficient of Determination Test (R2)**

**Table 10. Results of the Coefficient of Determination (R2) Test**

R-Square	0.489901
Adjusted R-Squared	0.458246

According to Table 10, the R-squared value of 0.489901 (48,9%) indicates that Good Corporate Governance, Tax Planning, and Financial Distress have a moderate effect on earnings management. However, 51.1% may be impacted by other factors not considered.

**Path Analysis**

**Table 11. Path Analysis with Sobel Test**

	<i>T Statistics</i>	<i>P-Values</i>
Good Corporate Governance (X <sub>1</sub> ) → Earnings Management (Y)	-0.007283	0.9942
Tax Planning (X <sub>2</sub> ) → Earnings Management (Y)	-2.469571	0.0150
Financial Distress (X <sub>3</sub> ) → Earnings Management (Y)	-0.549969	0.5834
Good Corporate Governance (X <sub>1</sub> ) → Internal Control (Z) → Earnings Management (Y)	1.280046	0.2005

Tax Planning (X <sub>2</sub> ) → Internal Control (Z) → Earnings Management (Y)	-1.354213	0.1756
Financial Distress (X <sub>3</sub> ) → Internal Control (Z) → Earnings Management (Y)	1.495198	0.1348
Internal Control (Z) → Earnings Management (Y)	-2.128592	0.0354

Based on the analysis of the table above, the probability value for Good Corporate Governance is  $0.9942 > 0.05$ , and the t-statistic is  $-0.007283$ , indicating no significant influence; however, the direction of influence is negative, so H1 is rejected. The probability of Tax Planning is  $0.0150 < 0.05$ , and the t-statistic is  $-2.469571$ , indicating that Tax Planning has a significant negative influence; thus, H2 is accepted. The probability of Financial Distress is  $0.5834 > 0.05$ , with a t-statistic of  $-0.549969$ , indicating that financial distress does not significantly affect, but shows a negative direction; thus, H3 is rejected. The internal Control has a probability of  $0.0354 < 0.05$  and a t-statistic of  $-2.128592$ , indicating that internal Control significantly affects earnings management in a negative direction, thus H4 is accepted. The mediating effect of internal Control on Good Corporate Governance has a probability of  $0.200528 > 0.05$  and a t-statistic of  $1.280046$ , indicating a positive effect of internal Control and rejecting H5. The mediating effect of internal Control on tax planning has a probability of  $0.175668 > 0.05$  and a t-statistic of  $-1.354213$ , indicating no significant influence on the mediating effect and a negative direction, so H6 is rejected. The mediating effect of internal Control on financial distress has a probability of  $0.1348626 > 0.05$  and a t-statistic of  $1.495198$ , indicating that the mediating effect of internal Control on financial distress is not significant but shows a positive direction; thus, H7 is rejected.

**Discussion**

**The Influence of Good Corporate Governance on Earnings Management**

The empirical results show that Good Corporate Governance (GCG) does not significantly affect earnings management in SOEs. This indicates that formal governance structures alone are insufficient to reduce opportunistic financial reporting. Although agency theory suggests that governance mechanisms such as independent commissioners and audit committees should limit managerial opportunism, their implementation in SOEs may remain procedural rather than substantive. Institutional theory explains this condition through symbolic compliance and “decoupling,” where governance structures exist formally but are weak in practice. Political economy theory further highlights that SOEs operate under political and bureaucratic pressures, which may weaken governance independence and encourage earnings management to maintain legitimacy. Stewardship theory emphasizes that governance effectiveness depends on ethical leadership and organizational commitment, while signaling theory suggests that GCG may still provide indirect reputational benefits by strengthening stakeholder trust. In addition, weak disclosure quality and limited monitoring effectiveness may allow managers to continue manipulating earnings despite the formal implementation of governance systems. Therefore, governance effectiveness depends not only on formal structures but also on implementation quality, ethical culture, independent oversight, and transparency. These findings are consistent with Jesica (2020) & Nabilah et al. (2024), which found limited influence of GCG on earnings management.

**The Influence of Tax Planning on Earnings Management**

The findings indicate that tax planning has a significant negative effect on earnings management in SOEs, suggesting that effective tax planning reduces managerial incentives to manipulate earnings. From the agency theory perspective, tax planning may either encourage opportunism or improve efficiency; this study supports the latter view, where tax planning functions as a legal mechanism to optimize financial performance without relying on accounting

manipulation. Companies with structured tax planning systems also tend to demonstrate stronger compliance, transparency, and reporting discipline. Signaling theory explains that transparent tax planning sends positive signals regarding accountability and managerial competence, thereby strengthening stakeholder trust. Institutional and political economy theories further suggest that SOEs operate under strong regulatory and political scrutiny, encouraging more conservative and compliant tax practices. Stewardship theory also supports the view that managers prioritize organizational sustainability through ethical tax management. Moreover, effective tax planning may reduce pressure on managers to artificially improve profits because financial efficiency has already been achieved through legitimate fiscal strategies. Although prior studies report contradictory findings, the results align with Melinda et al. (2024) and Nugraha & Setyawati (2024), which found that tax planning reduces earnings management. Overall, the findings suggest that tax planning in SOEs functions more as a mechanism for efficiency, compliance, and legitimacy than as an opportunistic tool.

### **The Influence of Financial Distress on Earnings Management**

The results show that financial distress does not significantly affect earnings management in SOEs, although the relationship tends to be negative. While agency theory predicts that financial pressure increases incentives for earnings manipulation, the findings suggest that distressed SOEs focus more on organizational survival, operational recovery, and maintaining stability. Increased scrutiny from regulators, auditors, and government institutions may also limit managerial discretion and reduce opportunities for aggressive reporting practices. Institutional theory explains that SOEs face strong legitimacy pressures during financial distress, encouraging more conservative reporting behavior. Political economy theory highlights that SOEs often receive government support and institutional protection, reducing bankruptcy pressure compared to private firms. Stewardship theory further suggests that managers may prioritize long-term sustainability and stakeholder interests rather than opportunistic behavior during periods of crisis. In addition, financial distress may create competing managerial incentives, where pressure to maintain performance is offset by tighter supervision and limited operational flexibility. These findings are consistent with Cahyaningrum et al. (2022), Ridanti & Suryaningrum (2021), and Tannaya & Lasdi (2021), which also found no significant relationship between financial distress and earnings management. Overall, the findings indicate that the effect of financial distress depends heavily on governance quality, institutional pressure, and organizational context.

### **The Influence of Internal Control on Earnings Management**

The findings reveal that internal control has a significant negative effect on earnings management in SOEs. Strong internal control systems reduce managerial opportunities to manipulate financial statements by improving supervision, transparency, and accountability. According to agency theory, internal control reduces information asymmetry and limits managerial discretion through monitoring mechanisms such as internal audits, segregation of duties, and authorization procedures. Effective internal control also increases detection risk, discouraging opportunistic behavior. Signaling theory suggests that strong control systems enhance stakeholder confidence by signaling reliable financial reporting and good governance practices. Institutional theory emphasizes that internal control effectiveness depends on substantive implementation rather than ceremonial compliance. Political economy theory further explains that SOEs face strong public accountability and political scrutiny, encouraging more effective control systems. Stewardship theory highlights that ethical leadership and accountability culture strengthen the role of internal control in reducing manipulation. Additionally, effective internal control contributes to stronger organizational discipline and fraud prevention by ensuring that financial reporting procedures are continuously monitored and verified. These findings are consistent with Cahyaningrum et al. (2022) and Wilamsari et al.

(2022), which found that strong internal control significantly reduces earnings management. Overall, internal control functions not only as a technical monitoring mechanism but also as a governance instrument that enhances transparency and organizational discipline.

## **5. Conclusion**

This study concludes that formal governance mechanisms such as Good Corporate Governance (GCG) and financial distress are not the main determinants in reducing earnings management within SOEs. Although both variables show negative relationships with earnings management, their effects are insignificant, indicating that formal governance structures and financial pressure alone are insufficient to ensure conservative financial reporting. These findings reflect the gap between formal governance design and its substantive implementation within the complex political and institutional environment of SOEs.

In contrast, tax planning and internal control play a more significant role in reducing earnings management. Effective tax planning reduces managerial incentives to manipulate earnings by improving financial efficiency legally, while strong internal control systems strengthen monitoring, transparency, and accountability. However, internal control is unable to mediate the relationship between the independent variables and earnings management, suggesting that it functions more as an independent governance mechanism rather than an intermediary variable.

Theoretically, this study contributes to governance and earnings management literature by showing that operational control mechanisms are more effective than formal governance structures alone in influencing managerial behavior within SOEs. The findings also emphasize that governance effectiveness depends on implementation quality, ethical culture, monitoring effectiveness, and institutional conditions. Agency theory, institutional theory, and political economy theory further explain that managerial behavior in SOEs is shaped not only by economic incentives but also by political intervention, legitimacy pressure, and public accountability.

Practically, the findings highlight the importance of strengthening substantive internal control implementation and improving tax planning effectiveness to enhance transparency and accountability in SOEs. Governance reforms should therefore focus not only on formal structures but also on ethical culture, managerial accountability, supervision quality, and operational monitoring.

This study has several limitations. First, some variables were measured using limited proxies that may not fully represent the complexity of concepts such as GCG, internal control, financial distress, and earnings management. Second, the model only includes limited explanatory variables, while other important factors such as audit quality, ownership structure, political connections, managerial compensation, leverage, and organizational culture were excluded. Third, the study may still contain endogeneity bias because the relationships between governance, internal control, and earnings management may be reciprocal. Fourth, the findings are limited to Indonesian SOEs listed on the Indonesia Stock Exchange during 2018–2023, which limits generalizability to other sectors and countries. In addition, the relatively limited sample size and observation period may reduce the robustness of the findings.

Therefore, future research is recommended to include additional variables such as political connections, regulatory pressure, organizational culture, audit quality, ownership concentration, leverage, profitability, and managerial compensation to better explain earnings management behavior in SOEs. Future studies should also apply more advanced analytical methods such as GMM, SEM, or bootstrapping techniques to reduce endogeneity bias and improve result robustness. Expanding research to private firms, different industries, cross-country contexts, and longer observation periods is also recommended. Furthermore, mixed-method approaches combining quantitative and qualitative analysis may provide deeper insight

into why formal governance structures sometimes fail to reduce earnings management despite regulatory compliance and governance reforms.

## References

- Agustin, B. H., Jatmiko, U., & Ningrum, Y. S. (2023). Tax Planning, Deferred Tax Expense, And Liquidity On Earnings Management With Firm Size as a Variable Control. *International Conference of Business and Social Sciences*, 3(1), 29–40. <https://doi.org/10.24034/icobuss.v3i1.340>
- Ambarita, D., & Febyana, L. (2025). The Influence of Profit Management and Corporate Governance on Tax Aggressiveness. *Journal of Business, Social and Technology*, 6(1), 24–33. <https://doi.org/10.59261/jbt.v6i1.266>
- Cahyaningrum, N., Gunawan, J., & Anis, I. (2022). Financial Distress dan Internal Control pada Earnings Management dengan Managerial Ownership Sebagai Moderasi. *E-Jurnal Akuntansi*, 32(6), 1506–1517. <https://doi.org/10.24843/EJA.2022.v32.i06.p09>
- Durana, P., Valaskova, K., Siekelova, A., & Michalkova, L. (2022). Appraisal of earnings management across the sectors. *Journal of Business Economics and Management*, 23(2), Article 2. <https://doi.org/10.3846/jbem.2022.16563>
- Edi, E. (2023). The Relation between CEO Reputation, Financial Distress, Internal Control, and Earnings Management. *Journal of Accounting Finance and Auditing Studies (JAFAS)*, 9(1), 154–171. <https://doi.org/10.32602/jafas.2023.007>
- Effendi, B. (2019). Professional Fee, Pergantian Chief Executive Officer (Ceo), Financial Distress, and Real Earnings Management. *Jurnal Ilmiah Akuntansi Dan Bisnis*, 4(2), Article 2. <https://doi.org/10.38043/jiab.v4i2.2302>
- Eryanto, D., Jones, I. van E., & Lasthuizen, K. (2022). The troubling impact of political interference in Indonesian public sector institutions on ethical leadership credibility. *International Journal of Public Leadership*, 18(4), 319–336. <https://doi.org/10.1108/IJPL-10-2021-0056>
- Ghonia, I. A., & Darma, S. S. (2023). Pengaruh Tax Planning, Aktiva Pajak Tangguhan dan Beban Pajak Tangguhan Terhadap Earning Management. *MIZANIA: Jurnal Ekonomi Dan Akuntansi*, 3(1), 320–333. <https://doi.org/10.47776/mizania.v3i1.611>
- Gulo, M. M., & Mappadang, A. (2022). Pengaruh Beban Pajak Tangguhan, Aset Pajak Tangguhan Dan Perencanaan Pajak Terhadap Manajemen Laba. *Ultimaccounting Jurnal Ilmu Akuntansi*, 14(1), 162–175. <https://doi.org/10.31937/akuntansi.v14i1.2627>
- Hadi, F., & Afriyenti, M. (2022). Pengaruh Internal Control dan Audit Eksternal terhadap Manajemen Laba AkruaI dan Riil. *Jurnal Eksplorasi Akuntansi*, 4(1), Article 1. <https://doi.org/10.24036/jea.v4i1.480>
- Iqbal, S., Andriani, F., & Hariadi, B. (2023). Does Good Corporate Governance (GCG) Moderate The Sustainability Report Disclosure And Earnings Management Relationship? *Assets: Jurnal Akuntansi Dan Pendidikan*, 12(2), Article 2. <https://doi.org/10.25273/jap.v12i2.15979>
- Ismail, T. H., Samy El-Deeb, M., & Abd El-Hafiezz, R. H. (2024). Ownership structure and financial reporting integrity: The moderating role of earnings quality in Egyptian practice. *Journal of Humanities and Applied Social Sciences*, 6(5), 471–495. <https://doi.org/10.1108/JHASS-06-2024-0076>
- Jesica, J. (2020). Pengaruh Good Corporate Governance Dan Ownership Structure Terhadap Real Earnings Management Dengan Audit Quality Sebagai Variable Moderasi. *Prosiding Seminar Nasional Pakar*, 2.59.1-2.59.1. <https://doi.org/10.25105/pakar.v0i0.6901>
- Jessica, E. I. (2021). Internal Control Sebagai Moderasi Dalam Hubungan Financial Distress Dengan Accrual Earnings Management. *Jurnal Paradigma Akuntansi*, 3(4), Article 4. <https://doi.org/10.24912/jpa.v3i4.15280>

- Juliana, A. N., & Reskino, R. (2023). Internal Control Implementation and Earning Management: A Mediation Effect Testing. *MAKSIMUM: Media Akuntansi Universitas Muhammadiyah Semarang*, 13(2), Article 2. <https://doi.org/10.26714/mki.13.2.2023.195-208>
- Khairiyah, A., & Herawaty, V. (2020). Pengaruh Tax Planning, Kinerja Perusahaan, Dan Leverage Terhadap Real Earnings Management Dengan Ukuran Perusahaan Sebagai Variabel Moderasi (Studi Empiris Pada Perusahaan Yang Terdaftar Di Indeks LQ 45 Tahun 2016 – 2018). *Prosiding Seminar Nasional Pakar*, 2.17.1-2.17.1. <https://doi.org/10.25105/pakar.v0i0.6839>
- Krisnanda, K. (2024). Evolusi Isu Earnings Management Dalam Literatur Bisnis: Analisis Bibliometrik. *Jurnal Ilmiah Manajemen, Ekonomi, & Akuntansi (MEA)*, 8(2), Article 2. <https://doi.org/10.31955/mea.v8i2.4272>
- Le, Q. L., & Nguyen, H. A. (2023). The impact of board characteristics and ownership structure on earnings management: Evidence from a frontier market. *Cogent Business & Management*, 10(1), 2159748. <https://doi.org/10.1080/23311975.2022.2159748>
- Marbun, R. V., Putra, A. M., & Wijayanti, A. (2021). Koneksi Politik dan Manajemen Skandal: Sebuah Temuan Empiris Perusahaan BUMN. *Jurnal Riset Dan Aplikasi: Akuntansi Dan Manajemen*, 5(2), Article 2. <https://doi.org/10.33795/jraam.v5i2.002>
- Melinda, V., Onasis, D., & Apriliani, I. B. (2024). Pengaruh Perencanaan Pajak, Ukuran Perusahaan, Dan Kepemilikan Manajerial Terhadap Manajemen Laba. *Jurnal Akuntansi Kompetif*, 7(2), Article 2. <https://doi.org/10.35446/akuntansikompetif.v7i2.1579>
- Nabilah, R. R., Yunita, K., & Astarani, J. (2024). Pengaruh Foreign Ownership Terhadap Praktik Earnings Management Yang Dimoderasi Oleh Good Corporate Governance Pada Perusahaan Sektor Pertambangan Yang Terdaftar Di Bursa Efek Indonesia Tahun 2021-2023. *Jurnal Ekonomi Manajemen Sistem Informasi*, 6(1), 437–442. <https://doi.org/10.38035/jemsi.v6i1.3007>
- Nestiti, I. G., Satriawan, B., & Robin. (2025). Pengaruh Financial Distress, Free Cash Flow dan Profitabilitas terhadap Earnings Management dengan Firm Size sebagai Moderasi. *Al-Kharaj: Jurnal Ekonomi, Keuangan & Bisnis Syariah*, 7(1), Article 1. <https://doi.org/10.47467/alkharaj.v7i1.5081>
- Nugraha, D. R., & Setyawati, W. (2024). Pengaruh Ukuran Perusahaan, Tax Planning Dan Good Corporate Governance Terhadap Manajemen Laba. *IJMA (Indonesian Journal of Management and Accounting)*, 5(2), Article 2. [https://doi.org/10.21927/ijma.2024.5\(2\).%p](https://doi.org/10.21927/ijma.2024.5(2).%p)
- Poluan, S. J., & Wicaksono, A. A. (2019). Pengaruh Pengungkapan Good Corporate Governance Terhadap Nilai Perusahaan Pada Badan Usaha Milik Negara Yang Terdaftar Di Bursa Efek Indonesia Periode 2013-2017. *JIM UPB (Jurnal Ilmiah Manajemen Universitas Putera Batam)*, 7(2), Article 2. <https://doi.org/10.33884/jimupb.v7i2.1238>
- Prameswari, N. P. A. S., Suaryana, I. G. A. N., Sujana, I. K., & Rasmini, N. K. (2022). Good Corporate Governance Moderates the Effect of Corporate Social Responsibility Disclosure, Financial Distress, and Managerial Ability on Earnings Management with Variable. *International Journal of Business, Economics and Management*, 5(4), 453–462. <https://doi.org/10.21744/ijbem.v5n4.2038>
- Puspito, A., Kusubagio, R., & Qomariah, N. (2017). Pengaruh Kecerdasan Emosional, Motivasi Belajar, dan Kecerdasan Spiritual Terhadap Pemahaman Mata Kuliah Akuntansi Keperilaku. *Jurnal Sains Manajemen dan Bisnis Indonesia*, 7(1), Article 1. <https://doi.org/10.32528/smbi.v7i1.1015>
- Putri, K. D., Masnila, N., & Oktarida, A. (2023). Analisis Kontribusi Laba Bumn Sektor Jasa Infrastruktur Terhadap Pendapatan Negara 2011-2020. *Jurnal Riset Terapan Akuntansi*, 7(1), Article 1. <https://jurnal.polsri.ac.id/index.php/jrtap/article/view/4983>
- Putri, M., & Naibaho, E. A. B. (2022). The Influence Of Financial Distress, Cash Holdings, And Profitability Toward Earnings Management With Internal Control As A Moderating

- Variable: The Case Of Listed Companies in ASEAN Countries. *Jurnal Akuntansi Dan Keuangan Indonesia*, 19(1), 120–138. <https://doi.org/10.21002/jaki.2022.06>
- Rachmawati, N. A., & Fitriana, A. (2021). The Effect of Financial Constraints and Institutional Ownership on Tax Agressiveness. *ACCRUALS (Accounting Research Journal of Sutaatmadja)*, 5(01), Article 01. <https://doi.org/10.35310/accruals.v5i01.606>
- Ridanti, P. P., & Suryaningrum, D. H. (2021). The Effect Of Financial Distress, Internal Control, And Debt Structure On Earnings Management In Companies Registered in the Indonesian Stock Exchange. *Jurnal Akuntansi*, 5(3), 458–472. <https://doi.org/10.36555/jasa.v5i2.1630>
- Romantis, O., Heriansyah, K., D.w, S., & Azizah, W. (2020). Pengaruh Perencanaan Pajak Terhadap Manajemen Laba Yang Di Moderasi Oleh Penurunan Tarif Pajak (Diskon Pajak). *Jurnal Ilmiah Akuntansi Dan Manajemen*, 16(1), 85–95. <https://doi.org/10.31599/jiam.v16i1.116>
- Rosyanna, O., Mansur, F., & Zulma, G. W. M. (2023). Pengaruh Fungsi Pengawasan Internal dan Eksternal Perusahaan, dan Financial distress terhadap Manajemen Laba. *Jurnal Ilmiah Universitas Batanghari Jambi*, 23(3), 3424. <https://doi.org/10.33087/jiubj.v23i3.4277>
- Saleh, M., Suryani, A., & Akbar, A. (2023). Pengaruh Hubungan Istimewa dan Good Corporate Governance terhadap Kebijakan Deviden dengan Manajemen Laba Sebagai Variabel Intervening pada Perusahaan Manufaktur yang Terdaftar di Bursa Eefek Indonesia Tahun 2016-2021. *J-MAS (Jurnal Manajemen Dan Sains)*, 8(2), 1569. <https://doi.org/10.33087/jmas.v8i2.1404>
- Sari, E., & Karlina, L. (2024). Pengaruh Tax Planning, Aset Pajak Tangguhan dan Beban Pajak terhadap Manajemen Laba (Studi Empiris pada Perusahaan Sektor Makanan dan Minuman yang Terdaftar di Bursa Efek Indonesia Tahun 2018 – 2022). *AKADEMIK: Jurnal Mahasiswa Ekonomi & Bisnis*, 4(3), Article 3. <https://doi.org/10.37481/jmeh.v4i3.908>
- Sari, M., Hanum, S., & Rahmayati, R. (2022). Analisis Manajemen Resiko Dalam Penerapan Good Corporate Governance: Studi pada Perusahaan Perbankan di Indonesia. *Owner : Riset Dan Jurnal Akuntansi*, 6(2), Article 2. <https://doi.org/10.33395/owner.v6i2.804>
- Simbolon, G. P. E., & Sudjiman, L. S. (2022). Pengaruh Tax Planning Terhadap Manajemen Laba Pada Perusahaan Manufaktur Sub-Sektor Makanan Dan Minuman Di Bursa Efek Indonesia Tahun 2019-2021. *Journal Scientific of Mandalika (JSM)*, 3(9), Article 9. <https://doi.org/10.36312/10.36312/vol3iss9pp5-13>
- Simon, A. Y. P., Wibowo, A. S., & Rosel, R. (2022). Pengaruh Penerapan Green Accounting Terhadap Kinerja Keuangan dengan Good Corporate Governance Sebagai Pemoderasi (Studi Empiris Pada Perusahaan Sektor Manufaktur yang Terdaftar di Bursa Efek Indonesia Periode 2016-2020). *Jurnal Manajemen Sains Dan Organisasi*, 3(3), Article 3. <https://doi.org/10.52300/jmso.v3i3.7543>
- Suheri, T. R. R., Fitriyani, D., & Setiawan, D. (2020). Analisis Pengaruh Beban Pajak Kini, Aset Pajak Tangguhan, Discretion Accrual, Dan Tax Planning Terhadap Manajemen Laba. *Jurnal Manajemen Terapan Dan Keuangan*, 9(03), Article 03. <https://doi.org/10.22437/jmk.v9i03.12043>
- Suwandi, S., Lambyombar, Y., Junaidi, M., & Yuliana, Y. (2024). Exploring Impact Factors on Earnings Management Practices. *Indo-Fintech Intellectuals: Journal of Economics and Business*, 4(6), 3173–3185. <https://doi.org/10.54373/ifijeb.v4i6.2404>
- Tannaya, C. I. N., & Lasdi, L. (2021). Pengaruh Financial Distress Terhadap Manajemen Laba Dengan Moderasi Corporate Governance. *JURNAL ILMIAH MAHASISWA AKUNTANSI*, 10(1), Article 1. <https://doi.org/10.33508/jima.v10i1.3453>
- Utami, A. T., & Ambarita, D. (2023). Pengaruh Perencanaan Pajak Terhadap Manajemen Laba Dengan Ukuran Perusahaan Sebagai Variabel Moderasi (Studi Empiris pada Perusahaan Makanan dan Minuman Yang terdaftar Di Bursa Efek Indonesia Tahun 2017 – 2021). *Jurnal Pajak Vokasi (JUPASI)*, 4(2), 24–33. <https://doi.org/10.31334/jupasi.v4i2.2586>

- Wilamsari, F., Wardayati, S. M., & Winarno, A. W. (2022). Financial Distress and Earnings Management: The Role of Internal Control as a Moderating Variable. *International Journal of Social Science and Business*, 6(3), Article 3. <https://doi.org/10.23887/ijssb.v6i3.46510>
- William, R., & Widjaja, I. (2024). Pengaruh tax planning, kepemilikan institusional, dan leverage terhadap manajemen laba pada perusahaan manufaktur yang terdaftar di BEI dengan profitabilitas sebagai variabel mediasi periode 2019-2022. *Jurnal Manajemen Bisnis Dan Kewirausahaan*, 8(2), 282–292. <https://doi.org/10.24912/jmbk.v8i2.29654>